



Document 2017 GW1556

Book 2017 Page 1556 Type 43 001 Pages 8
Date 5/17/2017 Time 10:51:54AM
Rec Amt \$.00

INDX
ANNO
SCAN
CHEK

LISA SMITH, COUNTY RECORDER
MADISON COUNTY IOWA

**REAL ESTATE TRANSFER - GROUNDWATER HAZARD STATEMENT
TO BE COMPLETED BY TRANSFEROR**

TRANSFEROR:

Name Ryan C. Clark

Address 1427 Walnut Lane Cumming IA 50061
Number and Street or RR City, Town or P.O. State Zip

TRANSFeree:

Name David Dose

Address 319 E 9th St. Storm Lake IA 50588
Number and Street or RR City, Town or P.O. State Zip

Address of Property Transferred:

1427 Walnut Lane Cumming IA 50061
Number and Street or RR City, Town or P.O. State Zip

Legal Description of Property: (Attach if necessary)

Parcel "A" located in the East Half (1/2) of the Northwest Quarter (1/4) of Section Twenty-five (25), Township Seventy-seven (77) North, Range Twenty-six (26) West of the 5th P.M., Madison County, Iowa, as shown in Plat of Survey filed in Book 3, Page 292, on July 9, 1998, in the Office of the Recorder of Madison County, Iowa, EXCEPT a tract of land located therein containing 0.497 acres, as shown in Plat of Survey filed in Book 2017, Page 1228, on April 19, 2017, in the Office of the Recorder of Madison County, Iowa, AND EXCEPT a tract of land located therein containing 0.503 acres, as shown in Plat of Survey filed in Book 2017, Page 1227, on April 19, 2017, in the Office of the Recorder of Madison County, Iowa.

1. Wells (check one)

- There are no known wells situated on this property.
- There is a well or wells situated on this property. The type(s), location(s) and legal status are stated below or set forth on an attached separate sheet, as necessary.

2. Solid Waste Disposal (check one)

- There is no known solid waste disposal site on this property.
- There is a solid waste disposal site on this property and information related thereto is provided in Attachment #1, attached to this document.

3. Hazardous Wastes (check one)

- There is no known hazardous waste on this property.
- There is hazardous waste on this property and information related thereto is provided in Attachment #1, attached to this document.

4. Underground Storage Tanks (check one)

- There are no known underground storage tanks on this property. (Note exclusions such as small farm and residential motor fuel tanks, most heating oil tanks, cisterns and septic tanks, in instructions.)
- There is an underground storage tank on this property. The type(s), size(s) and any known substance(s) contained are listed below or on an attached separate sheet, as necessary.

5. Private Burial Site (check one)

- There are no known private burial sites on this property.
- There is a private burial site on this property. The location(s) of the site(s) and known identifying information of the decedent(s) is stated below or on an attached separate sheet, as necessary.

6. Private Sewage Disposal System (check one)

- All buildings on this property are served by a public or semi-public sewage disposal system.
- This transaction does not involve the transfer of any building which has or is required by law to have a sewage disposal system.
- There is a building served by private sewage disposal system on this property or a building without any lawful sewage disposal system. A certified inspector's report is attached which documents the condition of the private sewage disposal system and whether any modifications are required to conform to standards adopted by the Department of Natural Resources. A certified inspection report must be accompanied by this form when recording.
- There is a building served by private sewage disposal system on this property. Weather or other temporary physical conditions prevent the certified inspection of the private sewage disposal system from being conducted. The buyer has executed a binding acknowledgment with the county board of health to conduct a certified inspection of the private sewage disposal system at the earliest practicable time and to be responsible for any required modifications to the private sewage disposal system as identified by the certified inspection. A copy of the binding acknowledgment is attached to this form.
- There is a building served by private sewage disposal system on this property. The buyer has executed a binding acknowledgment with the county board of health to install a new private sewage disposal system on this property within an agreed upon time period. A copy of the binding acknowledgment is provided with this form.
- There is a building served by private sewage disposal system on this property. The building to which the sewage disposal system is connected will be demolished without being occupied. The buyer has executed a binding acknowledgment with the county board of health to demolish the building within an agreed upon time period. A copy of the binding acknowledgment is provided with this form. [Exemption #9]
- This property is exempt from the private sewage disposal inspection requirements pursuant to the following exemption [Note: for exemption #9 use prior check box]: _____.
- The private sewage disposal system has been installed within the past two years pursuant to permit number _____.

Information required by statements checked above should be provided here or on separate sheets attached hereto:

I HEREBY DECLARE THAT I HAVE REVIEWED THE INSTRUCTIONS FOR THIS FORM

AND THAT THE INFORMATION STATED ABOVE IS TRUE AND CORRECT.

Signature:

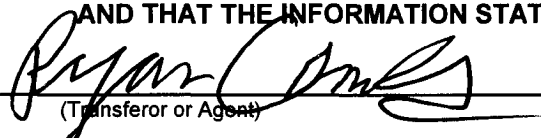
 (Transferor or Agent)

Telephone No.:

515 971 3909



Time of Transfer Inspection Report

Property Information

Current Owner: Deloris Applegate
 Buyer: Brian Clark Realtor: _____
 Mailing Address: 16611 335th St. Earlheim, Ia 50072
 Site Address/County: 1427 Walnut Ln Cumming, Ia 50061 / Madison County
 Legal Description As Abstract
 No. of bedrooms: 2 Last occupied: 12 months Records available: Y N
 Permit/ installation date: #161-05/11-22-05 Separation distances (ok/no?): OK

Septic System Information

Septic tank(s): Size: 1,250 gal Material: Concrete/Poly Condition: good
 Tank pumped? Y N Date: 12-12-11 Licensed pumper: Forest Septic
 Septic/Trash/Processing tank: Size: _____ Material: _____ Condition: _____
 Tank pumped? Y N Date: _____ Licensed pumper: _____
 Aerobic treatment unit (ATU) mfr _____ Size _____
 Tank pumped? Y N Date: _____ Licensed pumper: _____
 Maintenance contract? Y N Expiration date: _____ Service provider: _____
 Condition: _____
 Pump tanks/vaults: Type: Concrete/Poly Size: _____ Condition: _____
 Distribution system: Distribution box plastic Outlets used 4 Condition: good
 Header pipe(s): OK No. of lines: 4 Pressure dosed? no

Secondary Treatment:

Length of absorption fields: 4 75' laterals Determined by: probing
 Condition of fields: OK Determined by: Hydraulic Test and Probing
 Type of trench material: chambers
 Size of sand filter: _____ Determined by: _____
 Vent pipes above grade? Y N Discharge pipe located? Y N
 Effluent sample taken _____ Results: _____
 Media Filters: Type: _____
 Maintenance contract? Y N Expiration date: _____ Service provider: _____
 Condition: _____
 NPDES General Permit No. 4: Required? Y N Permitted? Y N NOI provided: _____



Time of Transfer Inspection Report

Other components:

Alarms: Y N Working: Y N Disinfection: Y N Working: Y N

Control Box: _____ Timers: _____ Inspection Ports: _____

Other components: _____

Overall condition of the private sewage disposal system:

Report system status: see notes

Explain (attach additional pages as needed): _____

Comments: _____

Site status at conclusion of Time of Transfer inspection:

- Verify that controls are set on the appropriate mode.
- Power is on to all components.
- Revisit all components to verify lids are secure.
- Gather all tools for removal from the site.
- Verify that no sewage is on the ground surface.

Using this worksheet, write a narrative report of the inspection results and attach a site sketch.

This report indicates the condition of the private sewage disposal system at the time of the inspection. It does not guarantee that it will continue to function satisfactorily.

Signature of Certified Inspector: Tory Forest Date: 12-12-16

Name (print): Tory Forest Certificate #: 10762

Address: PO Box 219, Indianola, IA 50125

Phone #: 515-360-7847

Provide a copy of this report, the narrative report and sketch to the seller/agent, buyer/agent or the person ordering the inspection, the county sanitarian/environmental health office and to:

Iowa DNR
Private Sewage Disposal Program
502 E 9th St
Des Moines IA 50319

DNR Time of Transfer Report System Status

Address: 1427 Walnut Ln. Date: 12-12-11

Technician Tory Forest

All waste water from house drains to septic system. Yes No However, the line
Remarks: coming from the house appears to have some
major blockage. possibly may have broken or pulled apart
The tank is a Poly Concrete 1,150 gallon tank. In good condition. Yes No

Remarks:

The distribution box is in good condition. Yes No None

Remarks:

The laterals are in good condition. Yes No None

Remarks:

This is not a guarantee!

- This certifies that the septic system was in good working condition at the time of the inspection.
- This certifies the condition of the septic system at the time of the inspection.

Permit No 161-05
Date of Inspection: 11-22-05
Contractor: Huff & Son
Existing Dwelling

Name: Christene Madson
Inspected by: Jean Thompson

1427 Walnut Lane
Cumming

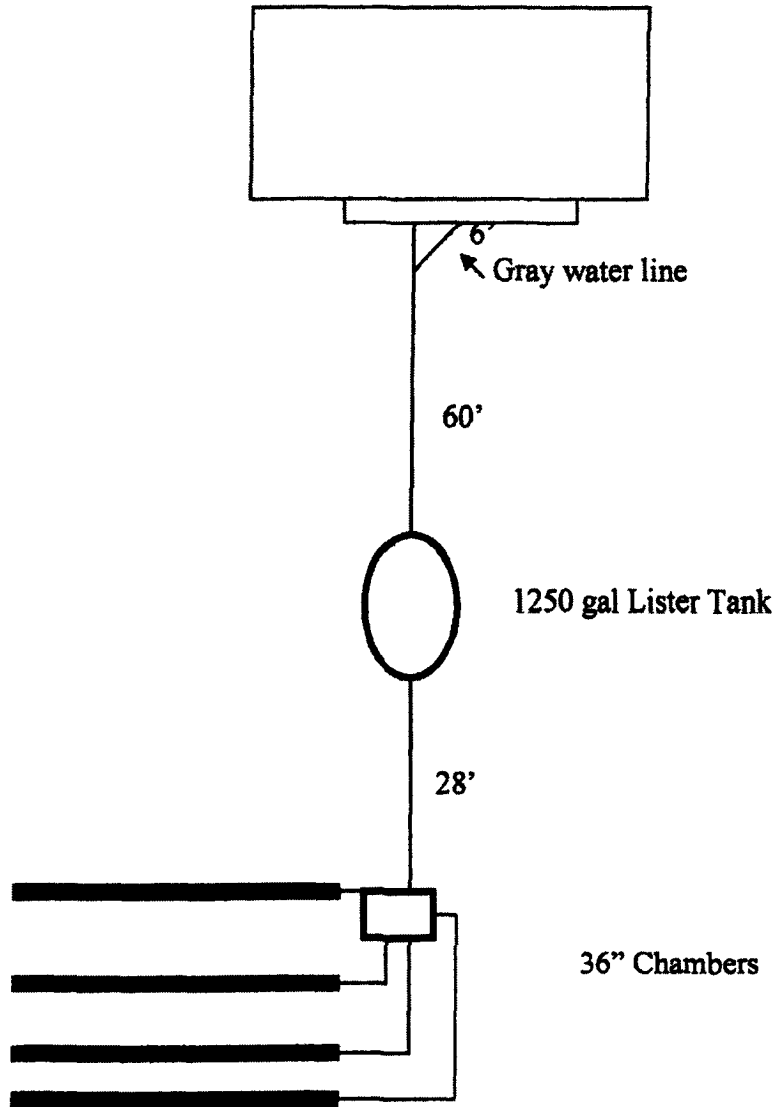

WildBlue Webmail

plforest@wildblue.net

62591 Deloris Applegate
Time Of Transfer

12-5-16 emailed madison co.
12-5-16 to Kate
12-16-16 emailed report

From : Your Website <info@forestseptic.com>

Fri, Dec 02, 2016 01:36 PM

Subject : Time Of Transfer

To : plforest@wildblue.net

No Pumping Info .

Reply To : info@forestseptic.com

Summary of web form submission:

Email Address

contact@email.com

Case Number

5292185

Order Form

Contact Person //> / First & Last Name: deloris applegate / Phone Number: (515)975-8021

About the Seller Agent or Realtor //> / First & Last Name: n/a / Email: contact@email.com / Phone (numbers only): ()-

About the Home //> / Address of Inspection: 1427 walnut lane / City: cumming State: IA Zip: 50061 / County: madison / Age of Septic System: 10 / Number of Bed Rooms: 2 / Occupied: no-Vacant-12-months / Water Service: yes Type: rural / Legal Description: / Township Name: 77 north / Section Number: 25 /

(2)
DNR

Mailing Address //> Owner's First & Last Name(s): deloris applegate / Owner's Mailing Address: 16611 335th pl / City: earlham State: IA Zip: 50072 / Phone: (515)975-8021 / Email: donrapplegate@gmail.com (3)

About the Buyer Agent or Realtor //> / Full Name : ryan and summer clark Name / Email: summerclark@iowareality.com hame@mail.com / Office Phone (000)000-0000 /

About the Buyer //> / Name(s): Bryan and summer clark Name(s) / Phone 000 900 0000 / Email: summerclark@iowareality.com / Address: 1430 walnut lane / City: cumming State: IA Zip: 50061 / Closing Date: 12-30-16 / Any Comments or Questions?

Close 12-30-16

Fwd: 1427 Walnut St.

Summer Clark

Wed 5/10/2017 2:07 PM

To:marcia@marciamunger.com <marcia@marciamunger.com>;

Here is the second half!

Sent from my iPhone

Begin forwarded message:

From: "Smith's Sewer Service" <smithsewerservice@gmail.com>
Date: January 14, 2017 at 12:53:23 PM CST
To: <summerclark@iowarealty.com>
Subject: 1427 Walnut St.

Hello,

On December 16,2016 our technician televised and cleaned the main sewer line to the septic tank, the line is clear and should be draining properly.

The customer was given the video of the televise inspection.

If you have any further questions, please feel free to call us at 255-6063

Thank You!