



Document 2012 GW2253

Book 2012 Page 2253 Type 43 001 Pages 5

Date 8/01/2012 Time 2:54 PM

Rec Amt \$.00

INDX ✓
ANNO
SCAN
CHEK

LISA SMITH, COUNTY RECORDER
MADISON COUNTY IOWA

**REAL ESTATE TRANSFER - GROUNDWATER HAZARD STATEMENT
TO BE COMPLETED BY TRANSFEROR**

TRANSFEROR:

Name Dale E. Tuttle and Nancy L. Tuttle
Address P.O. Box 489, Winterset, Iowa 50273
Number and Street or RR City, Town or P.O. State Zip

TRANSFeree:

Name Tyler S. Bass
Address 1571 - 210th Street, Winterset, Iowa 50273
Number and Street or RR City, Town or P.O. State Zip

Address of Property Transferred:
1571 - 210th Street, Winterset, Iowa 50273
Number and Street or RR City, Town or P.O. State Zip

Legal Description of Property: (Attach if necessary) Parcel "B" in the S½ SE¼ of Section 25, T76N, R29W, 5th P.M., Madison County, Iowa.

1. Wells (check one)

- There are no known wells situated on this property.
- There is a well or wells situated on this property. The type(s), location(s) and legal status are stated below or set forth on an attached separate sheet, as necessary.

2. Solid Waste Disposal (check one)

- There is no known solid waste disposal site on this property.
- There is a solid waste disposal site on this property and information related thereto is provided in Attachment #1, attached to this document.

3. Hazardous Wastes (check one)

- There is no known hazardous waste on this property.
- There is hazardous waste on this property and information related thereto is provided in Attachment #1, attached to this document.

4. Underground Storage Tanks (check one)

- There are no known underground storage tanks on this property. (Note exclusions such as small farm and residential motor fuel tanks, most heating oil tanks, cisterns and septic tanks, in instructions.)
- There is an underground storage tank on this property. The type(s), size(s) and any known substance(s) contained are listed below or on an attached separate sheet, as necessary.

5. Private Burial Site (check one)

- There are no known private burial sites on this property.
- There is a private burial site on this property. The location(s) of the site(s) and known identifying information of the decedent(s) is stated below or on an attached separate sheet, as necessary.

6. Private Sewage Disposal System (check one)

- All buildings on this property are served by a public or semi-public sewage disposal system.
- This transaction does not involve the transfer of any building which has or is required by law to have a sewage disposal system.
- There is a building served by private sewage disposal system on this property or a building without any lawful sewage disposal system. A certified inspector's report is attached which documents the condition of the private sewage disposal system and whether any modifications are required to conform to standards adopted by the Department of Natural Resources. A certified inspection report must be accompanied by this form when recording.
- There is a building served by private sewage disposal system on this property. Weather or other temporary physical conditions prevent the certified inspection of the private sewage disposal system from being conducted. The buyer has executed a binding acknowledgment with the county board of health to conduct a certified inspection of the private sewage disposal system at the earliest practicable time and to be responsible for any required modifications to the private sewage disposal system as identified by the certified inspection. A copy of the binding acknowledgment is attached to this form.
- There is a building served by private sewage disposal system on this property. The buyer has executed a binding acknowledgment with the county board of health to install a new private sewage disposal system on this property within an agreed upon time period. A copy of the binding acknowledgment is provided with this form.
- There is a building served by private sewage disposal system on this property. The building to which the sewage disposal system is connected will be demolished without being occupied. The buyer has executed a binding acknowledgment with the county board of health to demolish the building within an agreed upon time period. A copy of the binding acknowledgment is provided with this form. [Exemption #9]
- This property is exempt from the private sewage disposal inspection requirements pursuant to the following exemption [Note: for exemption #9 use prior check box]: _____
- The private sewage disposal system has been installed within the past two years pursuant to permit number _____

Information required by statements checked above should be provided here or on separate sheets attached hereto:

One active well is located Northwest of the machine shed.

I HEREBY DECLARE THAT I HAVE REVIEWED THE INSTRUCTIONS FOR THIS FORM AND THAT THE INFORMATION STATED ABOVE IS TRUE AND CORRECT.

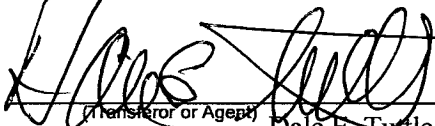
Signature: 
(Transferor or Agent)
Dale E. Tuttle

Telephone No.: (515) 468-0984



Realtor

Time of Transfer Inspection Report (DNR Form 542-0191)

Property information

Current owner Dale Tuttle
Buyer _____ Realtor Covered Bridge Realty
Mailing address _____ Winterset, Ia

Site Address/County 1571-210 rd St. Winterset, Ia 50273 Madison Co.
Legal Description _____

No. of bedrooms 3 Last occupied? is now Records available yes

Permit/installation date 12-2010 Separation distances ok/ no? OK
5012-10

Septic system information

Septic tank(s): size 1500 gal material concrete condition good
Tank pumped? no date never in 2010 licensed pumper _____
Septic/trash/processing tank: size _____ material _____ condition _____
Tank pumped? _____ date _____ licensed pumper _____

Aerobic treatment unit (ATU) mfg _____ size _____
Tank pumped? _____ date _____ licensed pumper _____
Maintenance contract? _____ expiration date _____ service provider _____
Condition _____

Pump tanks/vaults: type _____ size _____ condition _____

Distribution system: distribution box Plastic outlets used 6 condition good
Header pipe(s) 5 # of lines 6 Pressure dosed? _____

Secondary treatment:
length of absorption fields 50 ft determined by map + probing
condition of fields good determined by walking + probing
type of trench material 36" chamber

Size of sand filter _____ determined by _____
Vent pipes above grade? _____ discharge pipe located? _____
Effluent sample taken? _____ Results _____

Media filters: type _____
Maintenance contract? _____ expiration date _____ service provider _____
Condition _____

NPDES General Permit No. 4: required? _____ permitted? _____ NOI provided _____



Time of Transfer Inspection Report

Other components:

Alarms _____ Working? _____ disinfection _____ working? _____

Control box _____ Timers _____ inspection ports _____

Other components _____

Overall condition of the private sewage disposal system

Report system status The private sewage system at 1571-2nd St Winterset, Ia is in good cond.

Explain (attach additional pages as needed): The system was installed in 2010 and is in good cond. The septic tank was opened &

Comments: was at correct water level, if the tank effluent filter was cleaned also des. Box was looked at and all laterals took water on - 7-27-12 - also the lateral field was clean & dry.

Site status at conclusion of Time of Transfer inspection: all gray water goes to system on 7-27-12

- Verify that controls are set on the appropriate mode.
- Power is on to all components.
- Revisit all components to verify lids are secure.
- Gather all tools for removal from the site.
- Verify that no sewage is on the ground surface

Done

None on 7-27-12

Using this worksheet, write a narrative report of the inspection results and attach a site sketch.

This report indicates the condition of the private sewage disposal system at the time of the inspection. It does not guarantee that it will continue to function satisfactorily.

Signature of Certified inspector: John M. Mayer Date: 7-27-2012
 Name (print): **JOHN MAYER** Certificate #: 8979
 Address: **SEPTIC TANK PUMPING**
 Phone #: 515-462-2624 **1509 St. Hwy. 02**
Winterset, IA 50273-8411

Provide a copy of this report, the narrative report and sketch to the seller/agent, buyer/agent, the county sanitarian/environmental health office, county Recorder in the county the inspection was conducted and to;

Iowa DNR Onsite Wastewater Program
502 E. 9th St.
Des Moines, IA 50319

Mason Back →

DRIVE

1571-210th St
#012-10

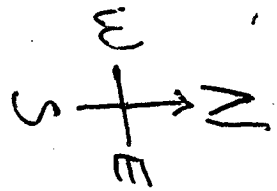

210th St

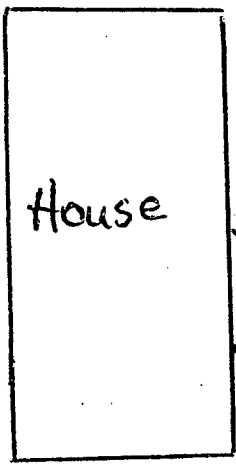

House

Collapsed existing tank + filled

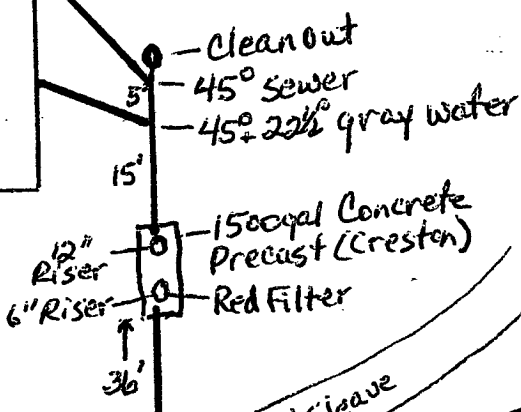

36'

limited use drive

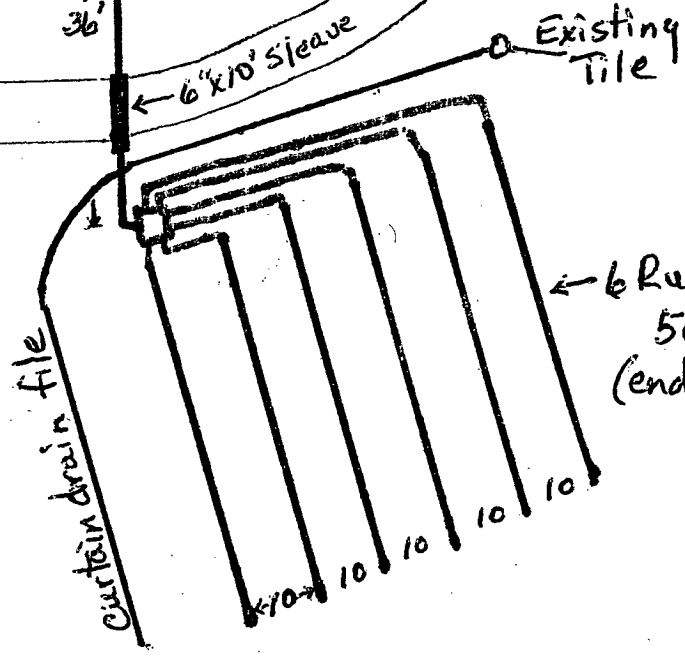

← 6 Runs 36" ARC
50' long 10' on center
(end caps screwed on)

Dale Tuttle
1571 210th St.
Winterset