

IND ✓
ANNK
SCAN
CHEF

LISA SMITH, COUNTY RECORDER
MADISON IOWA

07-645 VANCE & HOCHSTETLER, P.C. CONSULTING ENGINEERS, WINTERSSET, IOWA (515)462-3995
CHARLES T. VANCE, 110 WEST GREEN ST., WINTERSSET, IOWA 50273-1533
JAMES M. HOCHSTETLER, 110 WEST GREEN ST., WINTERSSET, IOWA 50273-1533

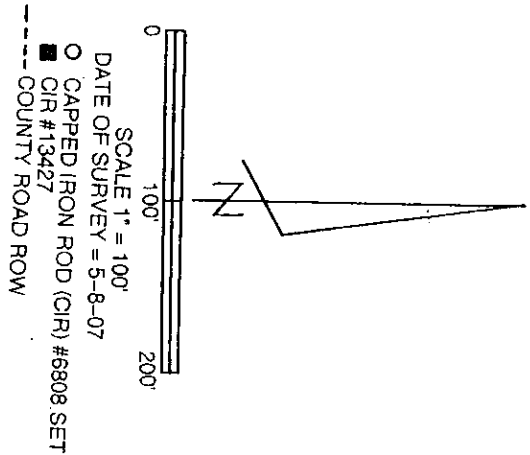
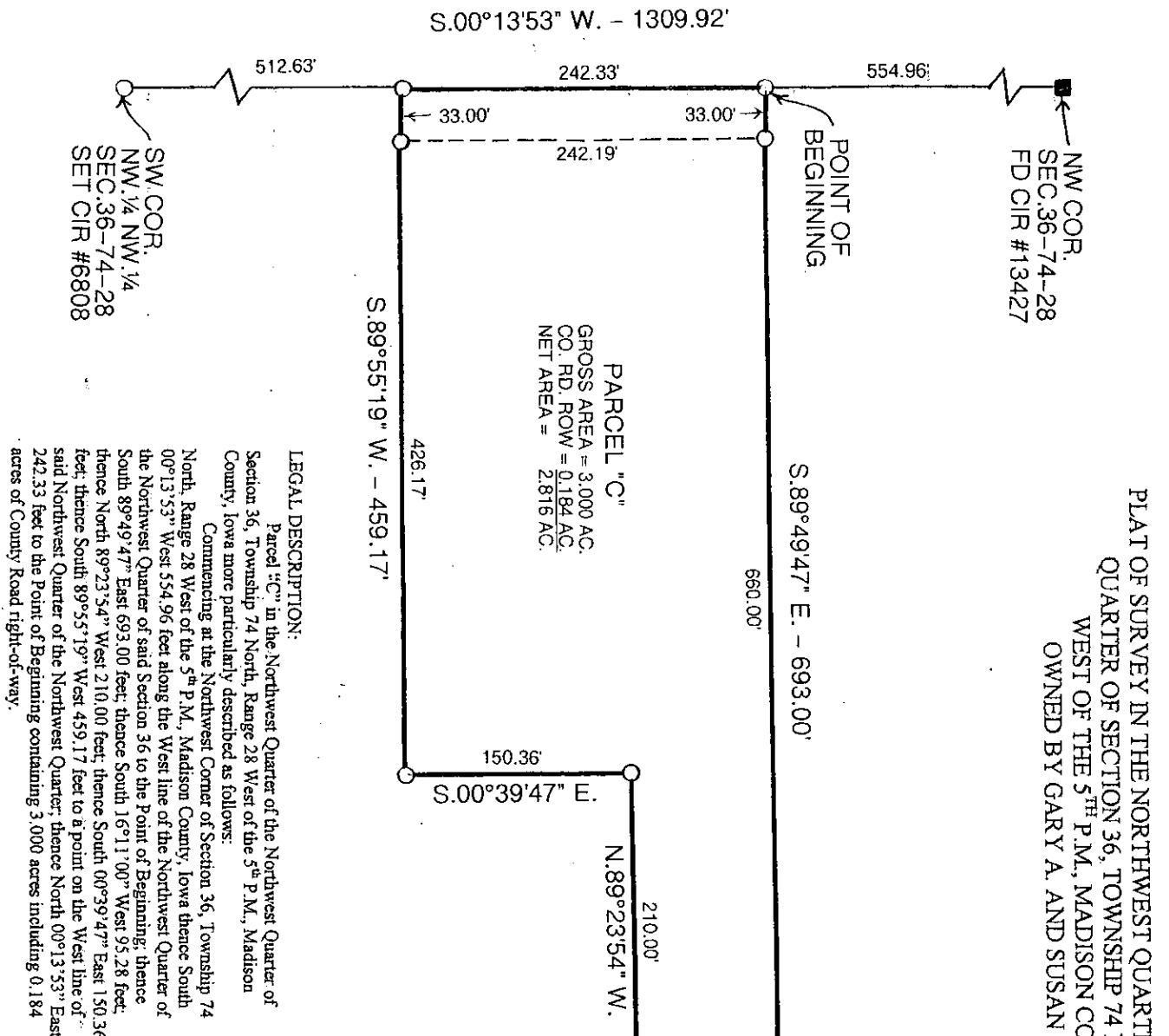

LICENSED LAND SURVEYOR
J. M. HOCHSTETLER
#6808
IOWA

I hereby certify that this land surveying document was prepared and the related survey work was performed by me or under my direct, personal supervision and that I am a duly licensed Land Surveyor under the laws of the State of Iowa.

J.M. HOCHSTETLER
License number 6808 Date 5/9/07
My license renewal date is December 31, 2007
Pages or sheets covered by this seal: 1