

MICHELLE UTSLER, COUNTY RECORDER
MADISON IOWA

COMPUTER	✓
RECORDED	✓
COMPALED	✓

LE

PLEASE RETURN TO:
MIDAMERICAN ENERGY ATTN: RIGHT-OF-WAY SERVICES P.O. BOX 657 DES MOINES, IA 50303-0657

Prepared by: Anne M. King (515) 281-2202

**MIDAMERICAN ENERGY COMPANY
UNDERGROUND ELECTRIC LINE EASEMENT**

Folder No. 337-06
Work Req. No. DR1963239
Project No. 61145

State of Iowa
County of Madison
Section 21
Township 77 North
Range 26 West of the 5th P.M.

KNOW ALL MEN BY THESE PRESENTS:

For and in consideration of the sum of One and no/100-----Dollar (\$1.00), and other valuable consideration, in hand paid by MIDAMERICAN ENERGY COMPANY, an Iowa Corporation, receipt of which is hereby acknowledged, the undersigned titleholders **R&J Construction, L.C., an Iowa limited liability company**, (Grantors), heirs and assigns, do hereby grant to MIDAMERICAN ENERGY COMPANY (Grantee), its successors or assigns, the right to lay, maintain, operate, repair, and remove underground conduit, wires, and other necessary equipment incident thereto (including associated surface mounted equipment) through and across certain property described below, together with ingress and egress to and from the same, and all the rights and privileges incident and necessary to the enjoyment of this grant.

In consideration of such grant, MIDAMERICAN ENERGY COMPANY agrees that it will repair or pay for any damage which may be caused to real and personal property of the undersigned by the construction, maintenance, operation, or removal of said line, except such property placed subsequent to the granting of this easement that interferes with the operation and maintenance of the line and associated equipment.

Additionally, MIDAMERICAN ENERGY COMPANY shall have the right to remove from the strip of land specifically described below, any obstructions; including trees, plants, undergrowth, buildings, and structures that interfere with the proper operation and maintenance of said line and equipment.

Grantors agree that they will not construct or place any permanent buildings, structures, trees, plants, or other objects on the property described below.

EASEMENT DESCRIPTION:

A 10-foot wide underground electric line easement situated in the property described as follows:

Lot Eighteen (18) of Woodland Valley Estates Plat No. 2 Subdivision located in the South Half (1/2) of the Northwest Quarter (1/4) of Section Twenty-one (21), Township Seventy-seven (77) North, Range Twenty-six (26) West of the 5th P.M., Madison County, Iowa, together with an undivided 1/29th interest in all common areas as set forth in the Declaration of Association for Woodland Valley Estates Subdivision filed in Book 2004, Page 6107 and in Book 2006, Page 2763 of the Madison County Recorder's Office.

Said electric easement being 5 feet on each side of the easement centerline described as follows: beginning at a point on the northerly margin of the cul-de-sac of Union Court, as it is presently established, that is 15 feet, more or less, easterly of the westerly line of said Lot Eighteen (18); thence northerly parallel with said westerly line a distance of 180 feet, more or less; thence westerly 15 feet, more or less, to the Point of Terminus on the westerly line of said Lot Eighteen (18), as depicted on Exhibit "A", attached hereto and made a part hereof.

This easement shall be binding upon the heirs, successors, and assigns of both parties. Grantors shall have the right of full enjoyment and use of the above-described property except as such that will be inconsistent with this easement.

Dated this 21 day of Sept, 2006

R&J Construction, L.C., an Iowa limited liability company

By: Ralph Schmitz manager
Ralph Schmitz
Its: Manager

ACKNOWLEDGMENT

STATE OF Iowa)
COUNTY OF Polk) ss

On this 21st day of September, 2006, before me, a Notary Public in and for the said State, personally appeared Ralph Schmitz, to me personally known, who being by me duly sworn did say that he is the Manager of **R&J Construction, L.C.**, an Iowa limited liability company, that said instrument was signed on behalf of said limited liability company by authority of its Operating Agreement, and the said Ralph Schmitz acknowledged the execution of said instrument to be the voluntary act and deed of said limited liability company, by it, and by him voluntarily executed.



Anne M. King
Notary Public in and for said State

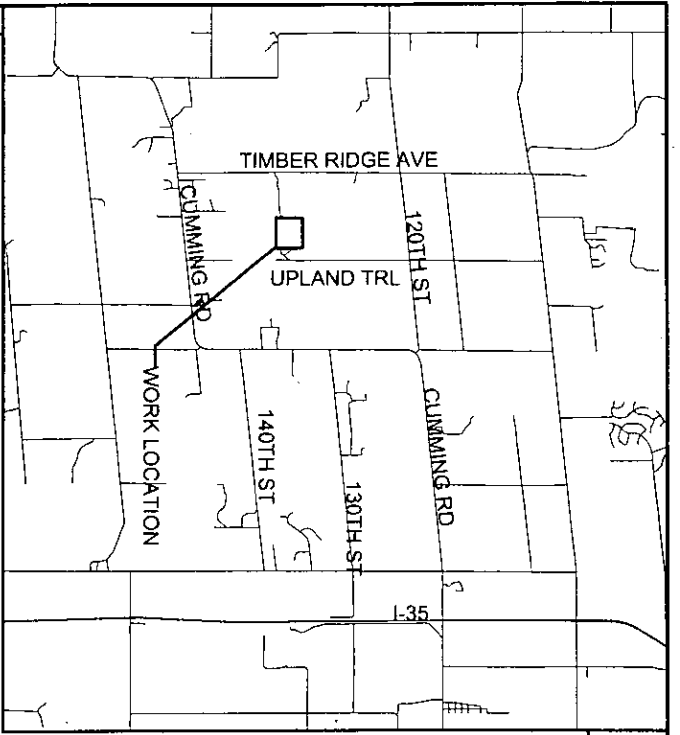

10' X 180' EASEMENT FROM
10' - 20' EWPL

17

0011641876
B PHS 50 KVA
120240

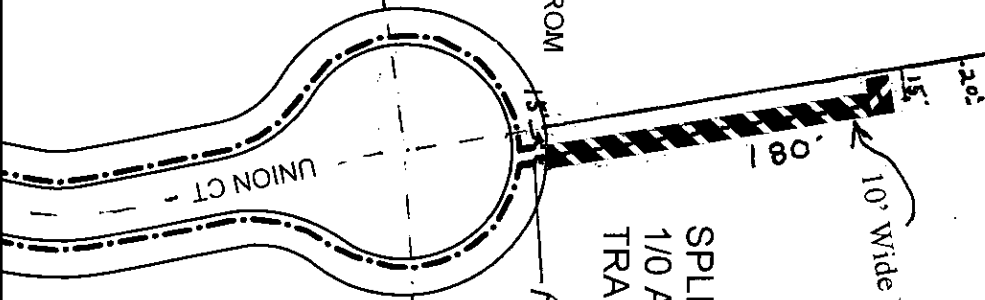

SPLICE IN TWO 180' RUNS
1/0 AL UG TO 50KVA
TRANSFORMER

Lot 18

EXHIBIT A

MADISON COUNTY
LEE TWP, SEC 21
77-26-21-67
CROSS ST = UPLAND LN

MidAmerican
Cust: R & J CONSTRUCTION
Addr: 0 UNION
City: MADISON COUNTY
Job Desc: PLAT 2 LOT 18 WOODLAND VALLEY ESTATES, SPLICE IN TWO 180' RUNS 1/0 AL UG TO 50KVA TRANSFORMER.

CT
X = 1540764 Y = 531817



WMMS_REV:1963239-1
Date: 9/6/2006
Scale: 1 in = 100 ft
Designer: WING PILCHER, ANNA R