

COMPUTER	<input checked="" type="checkbox"/>
RECORDED	<input checked="" type="checkbox"/>
COMPARED	<input type="checkbox"/>

MICHELLE UTSLER, COUNTY RECORDER
MADISON IOWA

Prepared By: Michael James Hackett, Madison County Engineer's Office, 1105 E. Court Ave., Winterset, Ia. 50273, Tel. (515) 462-1136

UNITED STATES PUBLIC LAND SURVEY CORNER CERTIFICATE OF

Land Survey Monuments situated in Section 9, Township 74 N, Range 28 W, of the Fifth Principal Meridian, Madison County, Iowa.
Previously recorded in Book 2004, Page 610 in County Recorder's Office.
(book, page, document number, etc.)

(Show reason for preparing this certificate, the evidence and detailed procedures used in establishing the corner positions and monumentation found or placed.)

Monument Description and Remarks: Previous monument disturbed during pavement replacement. Set P.K. nail in P.C.C. pavement. Established the corner position by using previous ties and ties established during construction of the pavement. The tie information was gathered during the reconstruction of the Madison County paving project STP-S-C061(72)--5E-61.

PLAN VIEW

(Show a minimum of three reference ties to durable physical objects, relevant monuments and physical conditions that will enable recovery of the corner.)

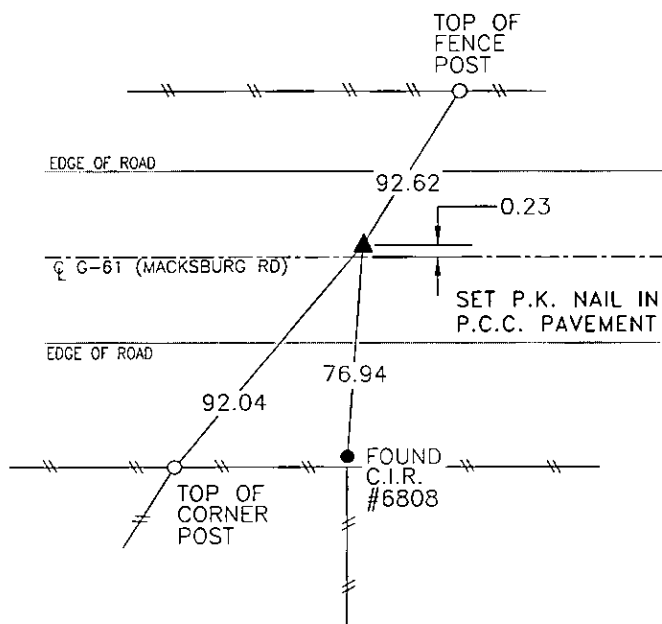
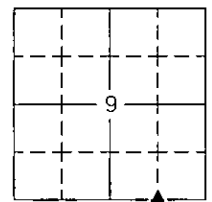

SW. COR., SE. 1/4, SE. 1/4, SEC. 9

NOTE: ALL TIES TO "X" NAILS UNLESS NOTED

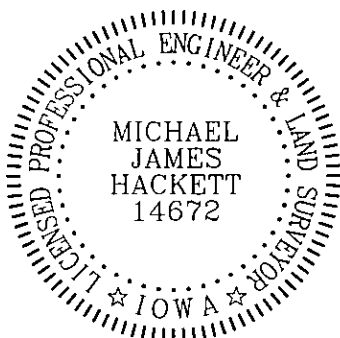

I hereby certify that this land surveying document was prepared and the related survey work was performed by me or under my direct personal supervision and that I am a duly Licensed Land Surveyor under the laws of the State of Iowa.

Signed Michael James Hackett Date 3/17/06
Michael James Hackett

Iowa license number 14672.
My license renewal date is 12/31/2006.
Pages covered by this seal: 1.