

5624

FILED NO. _____
BOOK 2003 PAGE 5624

2003 SEP 19 PM 2:49

MICKI UTSLER
RECORDER
MADISON COUNTY, IOWA

REC \$ 35⁰⁰
AUD \$ _____
R.M.F. \$ 1⁰⁰
5⁰⁰

COMPUTER
RECORDED
COMPARED

Prepared by and return to: Tim J. Bunkers - MidAmerican Energy Company - Right of Way Services
PO Box 446 Adair, IA 50002 800-891-6860

**MIDAMERICAN ENERGY COMPANY
OPTION FOR ELECTRIC LINE EASEMENT**

Tract No. IA-MD-023.000

State of Iowa, County of Madison

Legal Description: T77N, R29W, Section No. 12, of the 5th P.M.

Project No. B88

OPTION AND EASEMENT

The undersigned owner(s), Albert D. Von Rentzell and Joyce L. Von Rentzell, husband and wife, as joint tenants with full rights of survivorship and not as tenants in common, and the undersigned tenant(s), _____, collectively and individually, hereinafter referred to as "Grantor", in consideration of the sum of FIVE HUNDRED DOLLARS AND NO CENTS

(\$500.00) receipt of which is hereby acknowledged, grant to **MIDAMERICAN ENERGY COMPANY**, an Iowa corporation, its successors and assigns, hereinafter referred to as "Company", the right, for and during the period of twenty-four (24) months from the date hereof, to acquire for the further consideration of — 0 —

(\$— 0 —), hereinafter referred to as an "Option", upon exercise of said Option and as hereinafter agreed to, a perpetual right-of-way easement upon, over, under, across, and along the land situated in the County of Madison, State of Iowa, and as more specifically described and shown on the attached **Exhibit A**, and by this reference made a part hereof.

This right of way grant is for the purposes of constructing, reconstructing, patrolling, operating, maintaining and removing electric lines to be located on said premises, including the necessary pole structures, wires, and other appurtenances for the transmission of electric energy and communications, together with the power to extend to any other party the right to use, jointly with the Company, any structure placed pursuant to the terms hereof, such lines to form a part of an electric transmission system.

Consideration shall be paid to Grantor by Company to place no more than 0 pole structure(s) on said right-of-way. If the Company elects to place additional pole structures on said right-of-way, Company shall compensate Grantor the amount of Two thousand five hundred dollars (\$2,500.00) per additional pole structure.

Grantor Initial JUR A D V R
Revised 07-21-03
Revision 10

Company shall have the irrevocable right, commencing upon the date of the exercise of this Option, to survey the property; to conduct engineering and associated investigations including, but not limited to, core boring and soil testing; to trim or remove any trees or other vegetation growing in said easement area which, in the judgment of Company, may interfere with or endanger said electric lines; to install access gates to said easement area in the fences on the property of Grantor, and of ingress and egress over said land.

Damages to fences, livestock, crops or other property of Grantor, their successors and assigns, by Company while exercising any of the rights granted herein shall be paid by Company to the party damaged.

Subject to the rights of Company hereunder, Grantor shall have the right to cultivate, use and occupy the easement area hereinbefore described except that no structure or object, permanent or temporary, shall be erected, no wells shall be drilled, no storage of materials of any kind, nor shall any ground elevation changes be made, on said easement area without the written consent of Company, that no brush or other inflammable materials shall be deposited or accumulated or burned upon said easement area, and that no act shall be performed which violates the clearance requirements of the National Electrical Safety Code and/or the rules of the Iowa Utilities Board or its successor.

Upon exercise of the Option, all the foregoing provisions shall constitute the easement granted to the Company by Grantor.

LICENSE

During the period of the Option granted herein, Company shall have the irrevocable right, commencing upon the date of the execution of this instrument, to survey the property; to conduct engineering and associated investigations including, but not limited to, core boring and soil testing; to cut down, trim and spray any trees and shrubs growing in or adjacent to the above-described easement area as may be necessary, in the judgment of Company, to conduct the aforementioned surveys and investigations; and of ingress and egress over said land of Grantor.

Damages to fences, livestock, crops or other property of Grantor, their successors and assigns, by Company while exercising any of the rights granted herein shall be paid by Company to the party damaged.

Subject to the rights of Company hereunder, Grantor shall have the right to cultivate, use and occupy the easement area hereinbefore described except that no structure or object, permanent or temporary, shall be erected, no wells shall be drilled, no storage of materials of any kind, nor shall any ground elevation changes be made, on said easement area without the written consent of Company, that no brush or other inflammable materials shall be deposited or accumulated or burned upon said easement area, and that no act shall be performed which violates the clearance requirements of the National Electrical Safety Code and/or the rules of the Iowa Utilities Board or its successor.

Grantor Initial *JUR ADVR*
Revised 07-21-03
Revision 10

EXTENSION OF OPTION

The Company shall have the right, at the sole option of the Company, to extend the herein granted Option for a period of six months; said extension shall commence immediately upon expiration of the original Option. Consideration for said extension shall be Five hundred dollars (\$500.00), and shall be payable at the time of such extension.

EXERCISE OF OPTION

The Option granted herein shall be deemed exercised by Company, and the easement rights agreed upon herein shall be deemed granted, upon the recording of a Notice of Exercise of Option in the office of the Recorder of Deeds in the county in which the property is situated. A copy of the Notice of Exercise of Option shall be deposited in the United States mail in a prepaid sealed envelope addressed to Grantor at their last known address. A check, payable to Grantor in the amount of the further consideration stated above, shall accompany the Notice of Exercise of Option to the Grantor first above named.

TERMINATION OF OPTION

If the Company shall not elect to exercise the Option herein, or shall fail to exercise same within the time(s) hereinbefore provided, the Option shall terminate without further action and all rights granted hereunder shall become null and void.

It is mutually understood and agreed that this instrument covers all of the agreements and stipulations between the parties and that no representations or statements, oral or written, have been made modifying or changing the terms hereof.

Signed, sealed and delivered this 5th day of SEPTEMBER, 2003.

OWNER:

Joyce L. Von Rentzell
Joyce L. Von Rentzell
Albert D. Von Rentzell
Albert D. Von Rentzell

TENANT:

Grantor Initial JOR ADVR
Revised 07-21-03
Revision 10

ACKNOWLEDGEMENT

STATE OF IOWA)

SS)

COUNTY OF MADISON)

On this 8th day of September, A.D. 2003, before me, the undersigned, a Notary Public in and for the State of Iowa, personally appeared Albert D. Von Rentzell and Joyce L. Von Rentzell, to me known to be the identical persons named in and who executed the foregoing instrument, and acknowledged that they executed the same as their voluntary act and deed.



Jackie M Patterson
Iowa Notarial Seal
Commission number 721709
My Commission Expires 04/02/06



Notary Public in the State of Iowa

Exhibit A
Page 1 of 3

An electric line easement as depicted on attached parcel map, over, under and across that part of the SE ¼ of the SE ¼ of Section 12, in Township 77 North of Range 29 West of the 5th P.M. in Madison Co., Iowa and further described as follows:

Property Legal Description

A parcel of land described as follows: Beginning at the Southeast corner of Section Twelve (12), in Township Seventy-Seven (77) North, Range Twenty-Nine (29), West of the 5th P.M., Madison County, Iowa, thence West 944.60 feet, thence North 10 degrees 24' 48" East 462.54 feet, thence North 73 degrees 19' 00" East 62.59 feet, thence North 36 degrees 19' 35" East 190.37 feet, thence North 05 degrees 43' 52" East 616.57 feet, thence North 89 degrees 46' 06" East 279.42 feet, thence North 00 degrees 47' 09" East 530.02 feet, thence North 88 degrees 55' 30" East 344.96 feet to the East line of said Southeast Quarter (1/4) (also being the centerline of County Highway P-57), thence along said East line, South 00 degrees 09' 28" West 1777.33 feet to the Point of Beginning, containing 25.97 acres, more or less, including county roads, and 23.29 acres, more or less excluding county road, excepting therefrom a tract of land described as follows: Commencing at the Southeast corner of said Section Twelve (12), thence along the East line of the Southeast Quarter (1/4) of said Section, North 00 degrees 09' 28" East 935.81 feet to the point of beginning, thence North 86 degrees 02' 43" West 342.68 feet, thence North 00 degrees 33' 14" East 222.46 feet, thence North 87 degrees 56' 39" West 9.76 feet, thence North 00 degrees 23' 27" West 58.64 feet, thence North 00 degrees 47' 09" East 530.02 feet, thence North 88 degrees 55' 30" East 344.96 feet to the East line of said Southeast Quarter (1/4) (also being the centerline of County Highway P-57), thence along said East line, South 00 degrees 09' 28" West 841.52 feet to the point of beginning, containing 6.57 acres, more or less, including county road Right of Way.

Electric Line Easement Legal Description

That part of the above described tract of land being a continuous strip of land, 100 feet wide, situated fifty feet on each side of the following described centerline: Beginning at a point on the apparent West line; said point being 60 feet South of the NW corner of said tract; thence continuing easterly with said centerline approximately 300 feet to a point on the apparent East line of said tract. Said point being approximately 67 feet South of the NE corner of said tract. Section 12, Township 77 North, Range 29 West, of the 5th P.M.

The sidelines of said easement shall be considered lengthened or shortened to terminate at the property lines.

Note: All measurements are approximate.

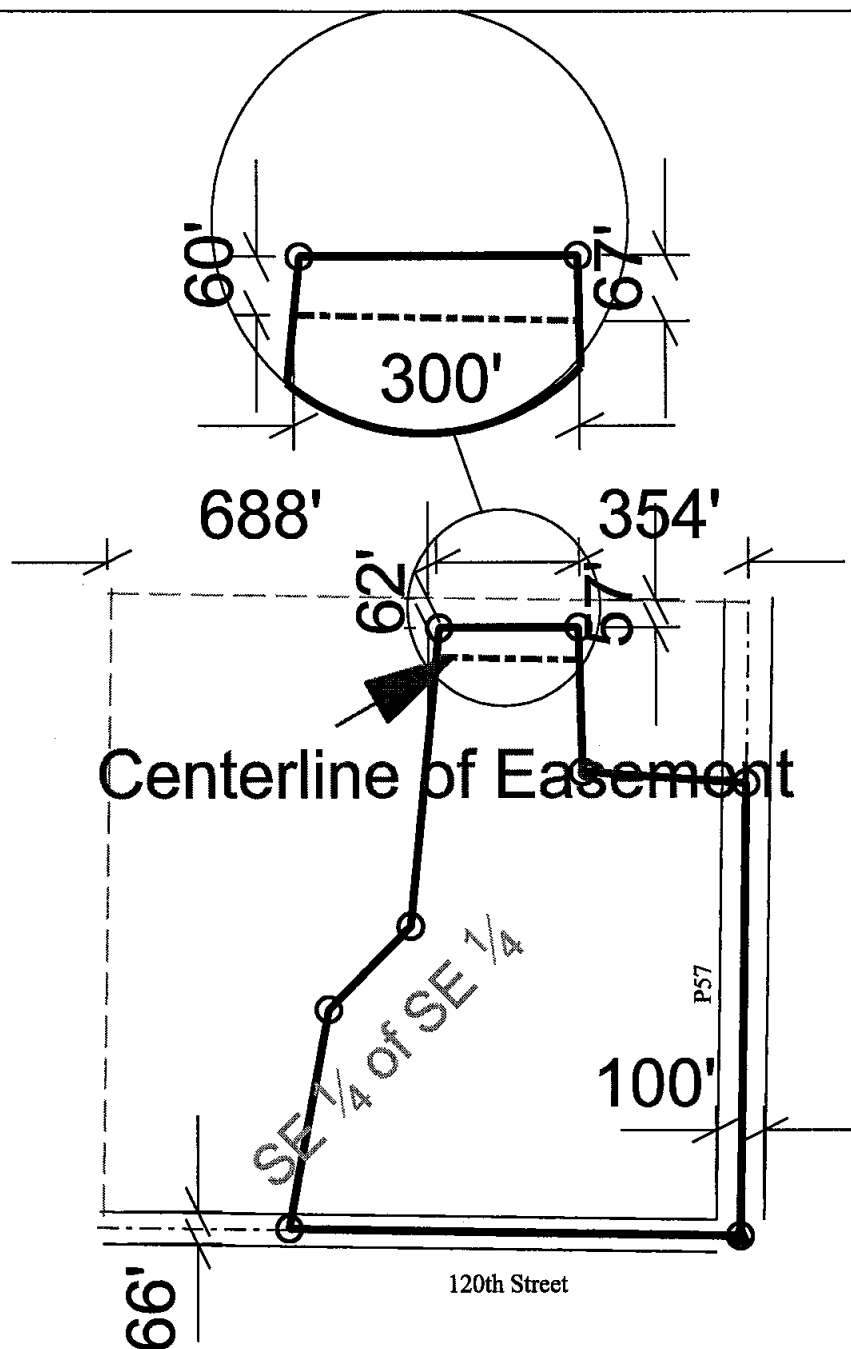

*ALL DIMENSIONS ARE APPROXIMATE DISTANCES

Owner

Albert D. Von Rentzell and
 Joyce L. Von Rentzell, husband
 and wife, joint tenants with full
 rights of survivorship, and not as tenants
 in common.

Albert D. Von Rentzell
 Joyce L. Von Rentzell
 1187 Earham Road
 Earham, IA 50072

Typical Pole Alignment

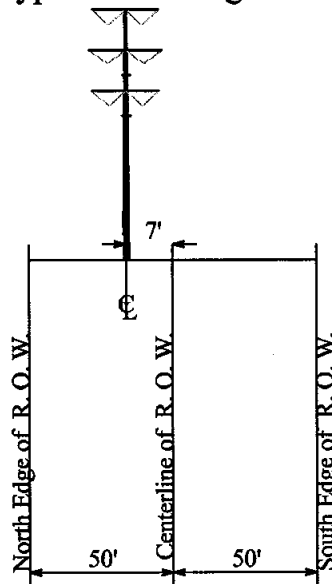

Legend

- Section Line & 1/4 Section Line
- 1/4 1/4 Section Line
- Property Line
- Property Corner
- ▲ Section Corner
- XXXXXX Easement

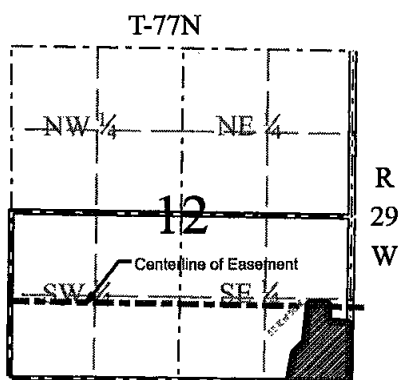

North



MidAmerican Energy Company		
Drawn By: JFT	Date: 8/7/03	Madison County
Rev:	Date:	
Rev:	Date:	
Rev:	Date:	
Exhibit A		Section 12, T-77N, R-29W
Page 3 of 3		
		Tract Number IA-MD-023.000