

Courthouse at Winterset  
Madison County, Iowa  
Built in 1876 of native limestone.

# Madison County Office of Zoning and Environmental Health

C. J. (Jeff) Nicholl, Administrator

REC \$ NO  
AUD \$ EE  
R.M.F. \$    

FILED NO. 004438

BOOK 2001 PAGE 4438

2001 OCT -2 PM 3: 05

MICKI UTSLER  
RECORDER  
MADISON COUNTY, IOWA

## VARIANCE PERMIT

COMPUTER   
RECORDED   
COMPARED

PERMIT NO: 2543

DATE: September 11, 2001

After the Public Hearing held on September 11, 2001, the Madison County Board of Adjustment hereby grants a Variance to Robert and Esther Trausch on the height restriction of 35 feet for a Light House on the following described real estate:

Section 25 T77 R26 Lee Township  
Lot 26 Plat 2 Walnut Cove - Deed Book 136 Page 179  
Cont Book 139 Page 615

A Variance of 6 feet has also been granted which will allow this Light Tower to be built to 41 feet. This Variance has been granted under the provision of Section 17, D.1.(b)(c) and D.2. (a) through (g).

Fred Howell, Chairperson  
Madison County  
Board of Adjustment

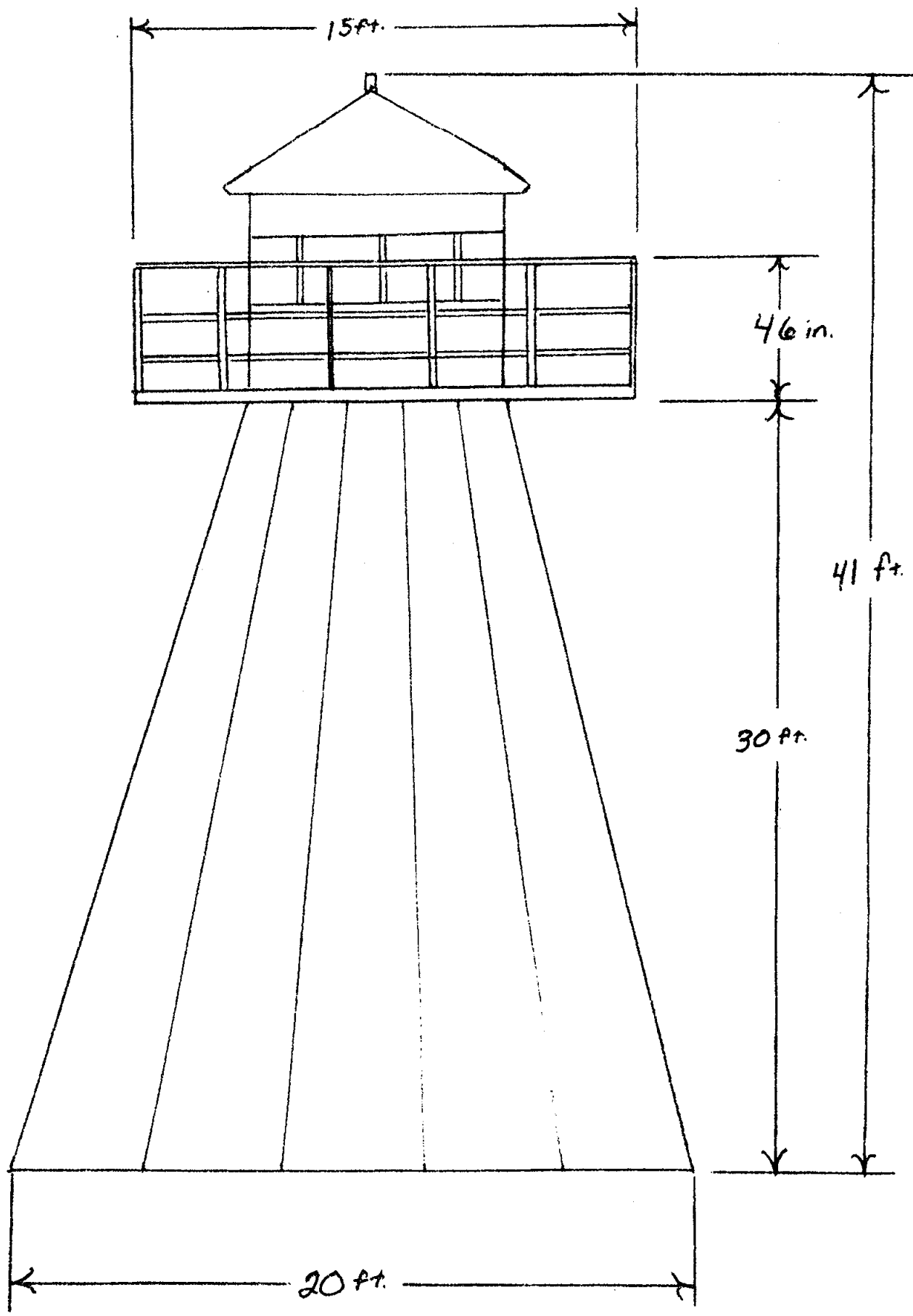

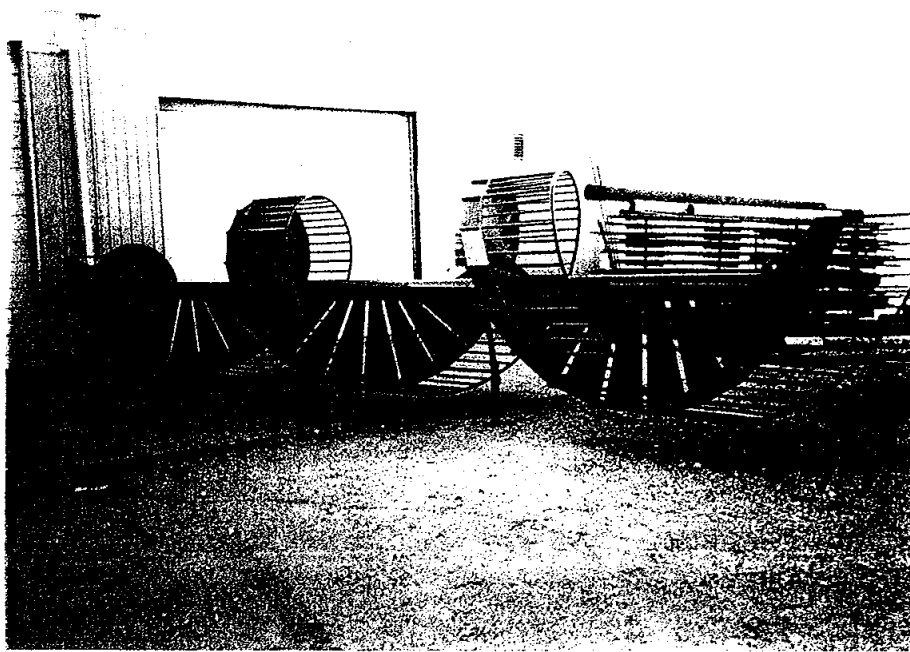

The Light House has a capacity of ten people. The staircase of the lighthouse is made of 8" schedule 40 pipe for center support. 1" Schedule 40 pipe for railing and 14 gauge square tubing uprights. 1/2" plate is used for the bottom of the railing. 14 gauge floor plate was for the steps. The lighthouse is then covered with plywood, and the plywood is covered in a plaster exterior. On the Very top of the lighthouse will be a maximum of a 150 watt stationary light bulb fixture. Our plans are to have this light fixture on a photocell. This allows for the light to automatically turn on at night and shutoff during the day. There should be no problem with this light disturbing any of the residents around the area.

The walnut cove residents will be members of the lighthouse association. Each member will have access to the locked lighthouse with a key. The purpose of this decorative lighthouse is for the enjoyment of a costal atmosphere, and to view the spectacular countryside the area offers.