



Document 2021 GW2584

Book 2021 Page 2584 Type 43 001 Pages 6

Date 6/23/2021 Time 1:45:49PM

Rec Amt \$.00

INDX
ANNO
SCAN

LISA SMITH, COUNTY RECORDER
MADISON COUNTY IOWA

CHEK

**REAL ESTATE TRANSFER - GROUNDWATER HAZARD STATEMENT
TO BE COMPLETED BY TRANSFEROR**

TRANSFEROR:

Name	<u>Brandon Brimm and Laura Brimm</u>			
Address	<u>P.O. Box 147</u>	<u>Macksburg</u>	<u>IA</u>	<u>50155</u>
	Number and Street or RR	City, Town or P.O.	State	Zip

TRANSFeree:

Name	<u>Laura Barnes and Jason Barnes</u>			
Address	<u>1887 Nature Court</u>	<u>Winterset</u>	<u>IA</u>	<u>50273</u>
	Number and Street or RR	City, Town or P.O.	State	Zip

Address of Property Transferred:

	<u>1887 Nature Court</u>	<u>Winterset</u>	<u>IA</u>	<u>50273</u>
	Number and Street or RR	City, Town or P.O.	State	Zip

Legal Description of Property: (Attach if necessary)

Lot Nineteen (19) of Copper Fox Estates Subdivision located in the East Half (E 1/2) of the Southeast Quarter (SE 1/4) of Section Seventeen (17), in Township Seventy-six (76) North, Range Twenty-seven (27) West of the 5th P.M., Madison County, Iowa

1. Wells (check one)

- There are no known wells situated on this property.
- There is a well or wells situated on this property. The type(s), location(s) and legal status are stated below or set forth on an attached separate sheet, as necessary.

2. Solid Waste Disposal (check one)

- There is no known solid waste disposal site on this property.
- There is a solid waste disposal site on this property and information related thereto is provided in Attachment #1, attached to this document.

3. Hazardous Wastes (check one)

- There is no known hazardous waste on this property.
- There is hazardous waste on this property and information related thereto is provided in Attachment #1 attached to this document.

4. Underground Storage Tanks (check one)

- There are no known underground storage tanks on this property. (Note exclusions such as small farm and residential motor fuel tanks, most heating oil tanks, cisterns and septic tanks, in instructions.)
- There is an underground storage tank on this property. The type(s), size(s) and any known substance(s) contained are listed below or on an attached separate sheet, as necessary.

5. Private Burial Site (check one)

- There are no known private burial sites on this property.
 There is a private burial site on this property. The location(s) of the site(s) and known identifying information of the decedent(s) is stated below or on an attached separate sheet, as necessary.

6. Private Sewage Disposal System (check one)

- All buildings on this property are served by a public or semi-public sewage disposal system.
 This transaction does not involve the transfer of any building which has or is required by law to have a sewage disposal system.
 There is a building served by private sewage disposal system on this property or a building without any lawful sewage disposal system. A certified inspector's report is attached which documents the condition of the private sewage disposal system and whether any modifications are required to conform to standards adopted by the Department of Natural Resources. A certified inspection report must be accompanied by this form when recording.
 There is a building served by private sewage disposal system on this property. Weather or other temporary physical conditions prevent the certified inspection of the private sewage disposal system from being conducted. The buyer has executed a binding acknowledgment with the county board of health to conduct a certified inspection of the private sewage disposal system at the earliest practicable time and to be responsible for any required modifications to the private sewage disposal system as identified by the certified inspection. A copy of the binding acknowledgment is attached to this form.
 There is a building served by private sewage disposal system on this property. The buyer has executed a binding acknowledgment with the county board of health to install a new private sewage disposal system on this property within an agreed upon time period. A copy of the binding acknowledgment is provided with this form.
 There is a building served by private sewage disposal system on this property. The building to which the sewage disposal system is connected will be demolished without being occupied. The buyer has executed a binding acknowledgment with the county board of health to demolish the building within an agreed upon time period. A copy of the binding acknowledgment is provided with this form. [Exemption #9]
 This property is exempt from the private sewage disposal inspection requirements pursuant to the following exemption [Note: for exemption #9 use prior check box]: ____.
 The private sewage disposal system has been installed within the past two years pursuant to permit number _____.

Information required by statements checked above should be provided here or on separate sheets attached hereto:

**I HEREBY DECLARE THAT I HAVE REVIEWED THE INSTRUCTIONS
FOR THIS FORM AND THAT THE INFORMATION STATED
ABOVE IS TRUE AND CORRECT.**

Signature: _____



(Transferor or Agent)

Telephone No.: (515) 494-6630

Time of Transfer Inspection Report

Property Information

Current Owner: Brandon Brimm

Buyer: _____ Realtor: _____

Mailing Address: _____

Site Address/County: 1887 Nature Court, Winterset IA/ Madison County

Legal Description _____

No. of bedrooms: 4 Last occupied: Current Records available: yes

Permit/ installation date: 6-26-12 Separation distances (ok/no?): ok

Septic System Information

Septic tank(s): Size: 1500 gal Material: Concrete Condition: good

Tank pumped? Y N Date: 5-4-21 Licensed pumper: Wiegert

Septic/Trash/Processing tank: Size: _____ Material: _____ Condition: _____

Tank pumped? Y N Date: _____ Licensed pumper: _____

Aerobic treatment unit (ATU) mfr _____ Size _____

Tank pumped? Y N Date: _____ Licensed pumper: _____

Maintenance contract? Y N Expiration date: _____ Service provider: _____

Condition: _____

Pump tanks/vaults: Type: _____ Size: _____ Condition: _____

Distribution system: Distribution box Plastic Outlets used 6 Condition: good

Header pipe(s): 4"sch40 No. of lines: 6 Pressure dosed? no

Secondary Treatment:

Length of absorption fields: _____ Determined by: _____

Condition of fields: _____ Determined by: _____

Type of trench material: _____

Size of sand filter: 40'x18' Determined by: County map

Vent pipes above grade? Y N Discharge pipe located? Y N

Effluent sample taken yes Results: see attached

Media Filters: Type: _____

Maintenance contract? Y N Expiration date: _____ Service provider: _____

Condition: _____

NPDES General Permit No. 4: Required? Y N Permitted? Y N NOI provided: _____



Time of Transfer Inspection Report

Other components:

Alarms: Y N Working: Y N Disinfection: Y N Working: Y N

Control Box: _____ Timers: _____ Inspection Ports: _____

Other components: _____

Overall condition of the private sewage disposal system:

Report system status: System was working properly during the inspection.

Explain (attach additional pages as needed): Tank is in good condition. D-box is in good condition.

Hydraulic test was good. All plumbing goes to the septic.

Comments: _____

Site status at conclusion of Time of Transfer inspection:

- Verify that controls are set on the appropriate mode.
- Power is on to all components.
- Revisit all components to verify lids are secure.
- Gather all tools for removal from the site.
- Verify that no sewage is on the ground surface.

Using this worksheet, write a narrative report of the inspection results and attach a site sketch.

This report indicates the condition of the private sewage disposal system at the time of the inspection. It does not guarantee that it will continue to function satisfactorily.

Signature of Certified Inspector: Ben Bedwell Date: 5-10-21

Name (print): Ben Bedwell Certificate #: 11612

Address: 1500 N B Street, Indianola IA

Phone #: 515-681-2053

Provide a copy of this report, the narrative report and sketch to the seller/agent, buyer/agent or the person ordering the inspection, the county sanitarian/environmental health office and to:

Iowa DNR
Private Sewage Disposal Program
502 E 9th St
Des Moines IA 50319

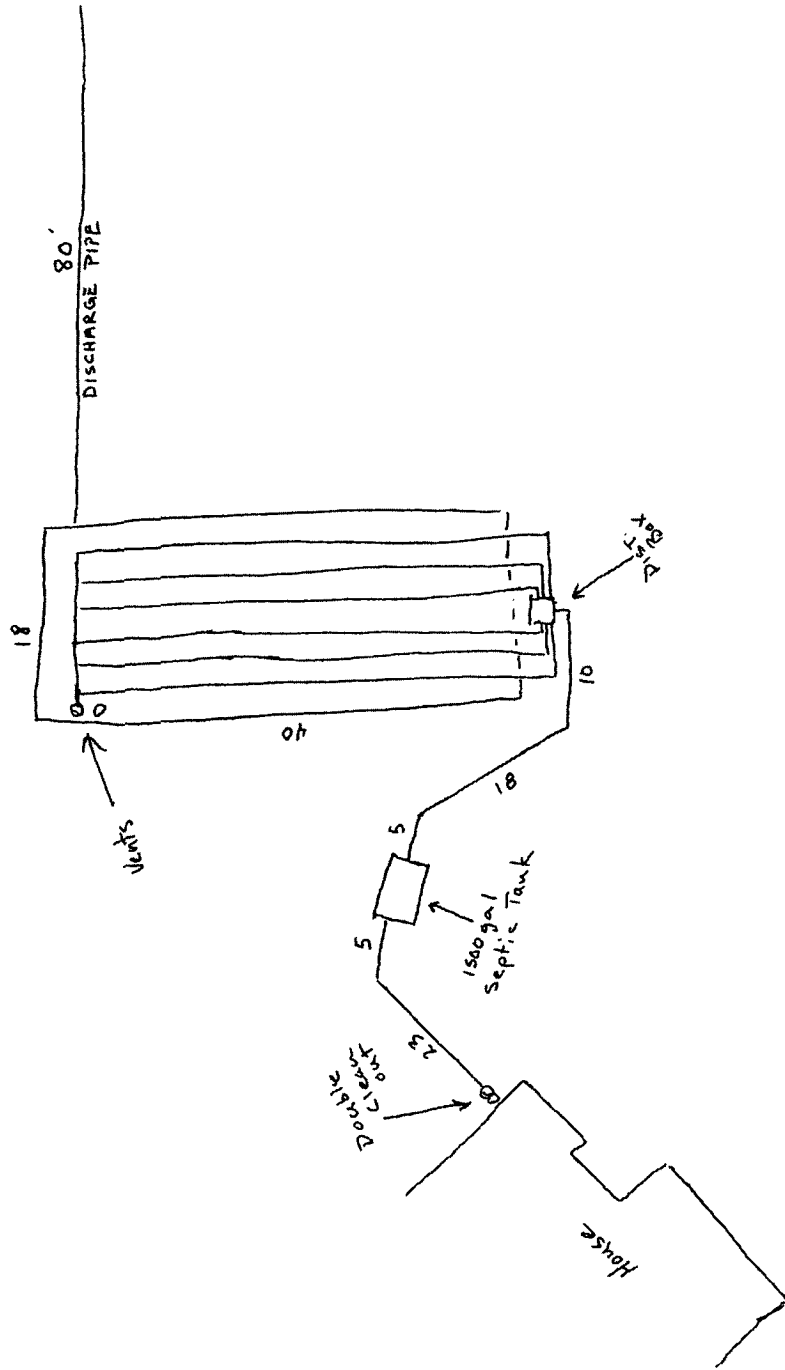

Permit # OZO-12
 1887 Nature Ct.
 Inspection 6/26/12



Collection Location septic discharge		Collector and Phone brimm brandon 515/494-6630	Client Reference brimm house	Accession # 1679447
WINTERSET, IA		Collected 2021-04-29 06:30	Received 2021-04-29 15:36	Project
Report To	BRANDON BRIMM 1887 NATURE CRT WINTERSET, IA 50273			Sample Description
				Sample Type Non-Drinking Water
				Sample Source
				Sample Note(s) 1

RESULTS OF ANALYSIS - FINAL REPORT

<u>TEST</u>	<u>RESULT (mg/L)</u>	<u>QUANT LIMIT</u>	<u>ANALYSIS NOTE(S)</u>
<i>BOD, Carbonaceous 5 Day, SM 5210 B</i> CBOD, 5 Day	<2	2	
<i>Total Suspended Solids, USGS I-3765-85</i> Total Suspended Solids	2	1	

SAMPLE AND ANALYSIS NOTES

1. Upon arrival, sample met container and preservation requirements for the analysis requested. Please review carefully your sample results for additional analyte comments or method exceptions.

ANALYSIS INFORMATION

<u>TEST</u>	<u>ANALYZED</u>	<u>SITE</u>	<u>RELEASED</u>	<u>ANALYSIS PREP</u>
1. BOD, Carbonaceous 5 Day, SM 5210 B	2021-04-29 16:30 AMG	3201	2021-05-05 07:44 MLS	
2. Total Suspended Solids, USGS I-3765-85	2021-04-30 10:00 KAR	3201	2021-05-03 16:01 AMG	

DESCRIPTION OF UNITS

mg/L = Milligrams per Liter

SITE(S) PERFORMING TESTING

3201 STATE HYGIENIC LABORATORY ANKENY, IOWA LABORATORIES COMPLEX, 2220 S ANKENY BLVD, ANKENY, IA 50023; Phone 515/725-1600; Fax 515/725-1642; Michael D. Schueller, M.S., Associate Director; Wade K. Aldous, Ph.D. (D)ABMM, Associate Director; IOWA ENVIRONMENTAL LAB ID #397

The result(s) of this report relate only to the items analyzed. Where the laboratory has not been responsible for the sampling stage the results apply only to the sample as received. This report shall not be reproduced except in full without the written approval of the laboratory. If you have any questions, please call Client Services at 800/421-IOWA (4692) or 319/335-4500.