

REAL ESTATE TRANSFER - GROUNDWATER HAZARD STATEMENT
TO BE COMPLETED BY TRANSFEROR

TRANSFEROR:

Name Scott Del Hessenius and Dianne Susan Hessenius
Address 2208 204th Court, Winterset, IA 50273
Number and Street or RR City, Town or P.O. State Zip

TRANSFeree:

Name Hivone S. Perez and Marcial Perez, Jr.
Address 4125 Ashworth Road, West Des Moines, IA 50265
Number and Street or RR City, Town or P.O. State Zip

Address of Property Transferred:
2208 204th Court, Winterset, IA 50273
Number and Street or RR City, Town or P.O. State Zip

Legal Description of Property: (Attach if necessary) See attached legal description.

1. Wells (check one)

- There are no known wells situated on this property.
 There is a well or wells situated on this property. The type(s), location(s) and legal status are stated below or set forth on an attached separate sheet, as necessary.

2. Solid Waste Disposal (check one)

- There is no known solid waste disposal site on this property.
 There is a solid waste disposal site on this property and information related thereto is provided in Attachment #1, attached to this document.

3. Hazardous Wastes (check one)

- There is no known hazardous waste on this property.
 There is hazardous waste on this property and information related thereto is provided in Attachment #1, attached to this document.

4. Underground Storage Tanks (check one)

- There are no known underground storage tanks on this property. (Note exclusions such as small farm and residential motor fuel tanks, most heating oil tanks, cisterns and septic tanks, in instructions.)
 There is an underground storage tank on this property. The type(s), size(s) and any known substance(s) contained are listed below or on an attached separate sheet, as necessary.

5. Private Burial Site (check one)

- There are no known private burial sites on this property.
- There is a private burial site on this property. The location(s) of the site(s) and known identifying information of the decedent(s) is stated below or on an attached separate sheet, as necessary.

6. Private Sewage Disposal System (check one)

- All buildings on this property are served by a public or semi-public sewage disposal system.
- This transaction does not involve the transfer of any building which has or is required by law to have a sewage disposal system.
- There is a building served by private sewage disposal system on this property or a building without any lawful sewage disposal system. A certified inspector's report is attached which documents the condition of the private sewage disposal system and whether any modifications are required to conform to standards adopted by the Department of Natural Resources. A certified inspection report must be accompanied by this form when recording.
- There is a building served by private sewage disposal system on this property. Weather or other temporary physical conditions prevent the certified inspection of the private sewage disposal system from being conducted. The buyer has executed a binding acknowledgment with the county board of health to conduct a certified inspection of the private sewage disposal system at the earliest practicable time and to be responsible for any required modifications to the private sewage disposal system as identified by the certified inspection. A copy of the binding acknowledgment is attached to this form.
- There is a building served by private sewage disposal system on this property. The buyer has executed a binding acknowledgment with the county board of health to install a new private sewage disposal system on this property within an agreed upon time period. A copy of the binding acknowledgment is provided with this form.
- There is a building served by private sewage disposal system on this property. The building to which the sewage disposal system is connected will be demolished without being occupied. The buyer has executed a binding acknowledgment with the county board of health to demolish the building within an agreed upon time period. A copy of the binding acknowledgment is provided with this form. [Exemption #9]
- This property is exempt from the private sewage disposal inspection requirements pursuant to the following exemption [Note: for exemption #9 use prior check box]: _____.
- The private sewage disposal system has been installed within the past two years pursuant to permit number _____.

Information required by statements checked above should be provided here or on separate sheets attached hereto:

I HEREBY DECLARE THAT I HAVE REVIEWED THE INSTRUCTIONS FOR THIS FORM AND THAT THE INFORMATION STATED ABOVE IS TRUE AND CORRECT.

Signature:  Telephone No.: (515) 556-6924
(Transferor or Agent)

EXHIBIT A

Lot One (1) of Woodland Hills Plat No. 1, an Addition to the City of Winterset, Madison County, Iowa; **AND** Parcel "G", a part of Lot 14, of C and C Allen's Addition to Winterset, Madison County, Iowa, containing 13.769 acres, as shown in Plat of Survey filed in Book 2, Page 389, on February 22, 1999, in the Office of the Recorder of Madison County, Iowa, **EXCEPT** Lot One (1) of said Woodland Hills Plat No.1; **AND** a tract of land located in the Northwest Fractional Quarter ($\frac{1}{4}$) of the Northwest Quarter ($\frac{1}{4}$) of Section Thirty (30), Township Seventy-six (76) North, Range Twenty-seven (27) West of the 5th P.M., Madison County, Iowa, containing 16.172 acres, as shown in Plat of Survey filed in Farm Plat Book 2, Page 94 on March 7, 1988, in the Office of the Recorder of Madison County, Iowa, **EXCEPT** the following described tracts, to-wit:

1. Parcel "D" located therein and containing 3.16 acres, as shown in the Amended Plat of Survey filed on May 21, 2003, in Book 2003, Page 2990 in the Office of the Recorder of Madison County, Iowa, and as amended by Affidavit filed on August 19, 2003, in Book 2003, Page 4934 in the Office of the Recorder of Madison County, Iowa;
2. Parcel "F" located therein, containing 3.50 acres, as shown in Amended Plat of Survey filed in Book 2003, Page 2990 on May 21, 2003, in the Office of the Recorder of Madison County, Iowa, and as amended by Affidavit filed August 19, 2003 in Book 2003, Page 4934 in the Office of the Recorder of Madison County, Iowa;
3. Lots 12 and 13 of C & C Allen's Addition to the City of Winterset, Madison County, Iowa;
4. That part thereof used or conveyed for highway purposes.

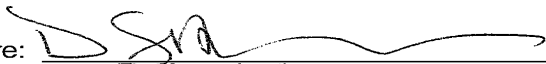

Time of Transfer Inspection Report

Property Information

Current Owner: Dianne and Scott Hessenius
 Buyer: _____ Realtor: Jennifer Stover
 Mailing Address: _____
 Site Address/County: 2208 204th Court Winterset/ Madison County
 Legal Description _____
 No. of bedrooms: 4 Last occupied: Current Records available: yes
 Permit/ installation date: 7-8-04 Separation distances (ok/no?): ok

Septic System Information

Septic tank(s): Size: 2,000 gal Material: concrete Condition: good
 Tank pumped? Y N Date: 7-10-20 Licensed pumper: Wiegert
 Septic/Trash/Processing tank: Size: _____ Material: _____ Condition: _____
 Tank pumped? Y N Date: _____ Licensed pumper: _____
 Aerobic treatment unit (ATU) mfg _____ Size: _____
 Tank pumped? Y N Date: _____ Licensed pumper: _____
 Maintenance contract? Y N Expiration date: _____ Service provider: _____
 Condition: _____
 Pump tanks/vaults: Type: Homemade Size: 500 gal Condition: good
 Distribution system: Distribution box plastic Outlets used 5 Condition: good
 Header pipe(s): 4"sch40 No. of lines: 5 Pressure dosed? yes
 Secondary Treatment:
 Length of absorption fields: 5x100' Determined by: County Records
 Condition of fields: good/dry Determined by: Hydraulic test
 Type of trench material: 36" Chambers
 Size of sand filter: _____ Determined by: _____
 Vent pipes above grade? Y N Discharge pipe located? Y N
 Effluent sample taken _____ Results: _____
 Media Filters: Type: _____
 Maintenance contract? Y N Expiration date: _____ Service provider: _____
 Condition: _____
 NPDES General Permit No. 4: Required? Y N Permitted? Y N NOI provided: _____



Time of Transfer Inspection Report

Other components:

Alarms: Y N Working: Y N Disinfection: Y N Working: Y N

Control Box: _____ Timers: _____ Inspection Ports: _____

Other components: _____

Overall condition of the private sewage disposal system: _____

Report system status: System working properly during inspection

Explain (attach additional pages as needed): The septic tank looks good. All plumbing goes to the septic. Pump tank looks good. D-box looks good. Hydraulic test good. Pump and alarm were working.

Comments: _____

Site status at conclusion of Time of Transfer inspection:

- Verify that controls are set on the appropriate mode.
- Power is on to all components.
- Revisit all components to verify lids are secure.
- Gather all tools for removal from the site.
- Verify that no sewage is on the ground surface.

Using this worksheet, write a narrative report of the inspection results and attach a site sketch.

This report indicates the condition of the private sewage disposal system at the time of the inspection. It does not guarantee that it will continue to function satisfactorily.

Signature of Certified Inspector: Ben Bedwell Date: 7-19-20

Name (print): Ben Bedwell Certificate #: 11612

Address: 1500 N B Street, Indianola

Phone #: 515-681-2053

Provide a copy of this report, the narrative report and sketch to the seller/agent, buyer/agent or the person ordering the inspection, the county sanitarian/environmental health office and to:

Iowa DNR
Private Sewage Disposal Program
502 E 9th St
Des Moines IA 50319

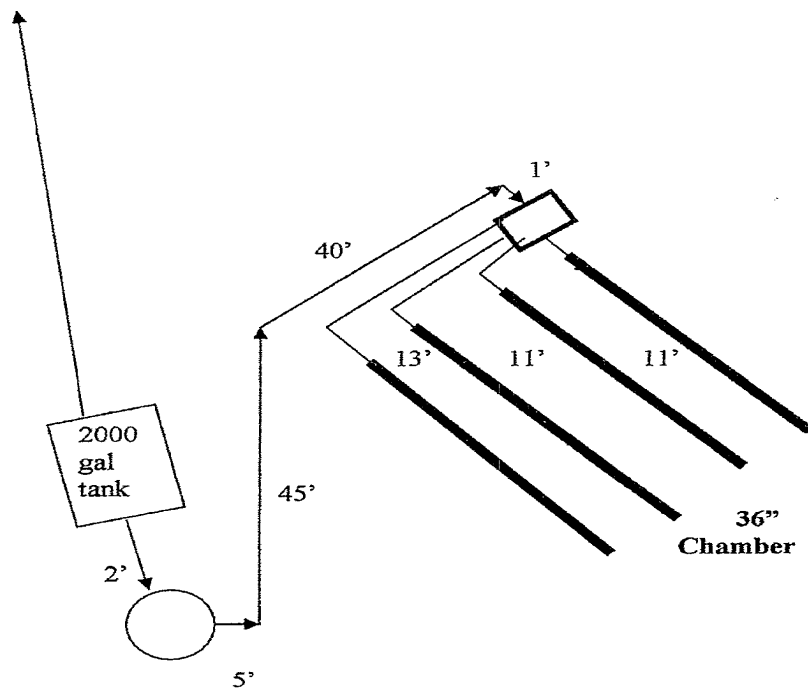

Used perc test from Vance & Hochstettler dated 6-24-04 500' 5 @ 100. Used 36" Chamber and reduced 25%